

start the engine! Replace the valve cover or tighten the oil line fittings, then start the engine. Do not allow engine to idle below 2,000 RPM during break-in. Run the engine at a fast idle (with a cooling fan in place), or ride gently for approximately 30 minutes to break in you new cam.

- After engine has been run for at least an hour, let it cool and re-check the valve clearance. Clearances may have changed slightly during the break-in period, and re-adjustment at this time is important for cam longevity and quiet engine operation.

#### PERFORMANCE TIPS

- If your engine is worn out, installing a performance cam won't make it better. If at all possible, at least have a valve job.
- Some performance cams may take away low-end power. The power can be regained by installing a High compression piston (high octane fuel required), or installing a Powroll bore and/or stroker kit.
- By advancing or retarding the cam timing you can tailor the power curve of your engine. Typically, advancing the cam 2 to 4 degrees will increase the low end power. Retarding the cam 2 to 4 degrees may enhance top end power. Before attempting to change your cam timing, be sure the valve pockets are deep enough to keep the valves from hitting the piston. See the cam spec sheet for minimum clearances. Clearances can be checked by claying the top of the piston.
- Performance cams require other engine modifications to work properly. For instance, a radical cam will not work well in a stock engine. The engine will tend to stutter and act like it is loading up during acceleration.
- **Matching all your performance parts with those from the same manufacturer, and following manufacturers recommendations will give you the best performance. "Mix and match" parts from various companies may not be compatible, and could actually take away horsepower!**

Powroll Inc.

4115 SW 19<sup>th</sup> St • Redmond OR 97756

Phone: 541-923-1290 Fax: 541-923-5637

mail@powroll.com • www.powroll.com



### CAMSHAFT SPECIFICIFICATIONS

Engine Model **DRZ – KLX 125  
DR 125**

**Cam #12616B**

	OPEN	CLOSE	VALVE LIFT	RUNNING CLEARANCE
INLET	3° BTDC	37° ABDC	.280"	.005"
EXH	38° BBDC	3° ATDC	.270"	.007"

OK to install cam on stock timing marks?	YES
OK to use stock Valve Springs?	YES
Must check that cam will rotate without interference?	YES
Must check for valve to valve clearance	NO
Must check for spring retainer to valve guide clearance?	*NO
Check for coil bind?	**YES

#### VALVE TO PISTON CLEARANCE WITH THIS CAM

Powroll cams are designed to work with Powroll pistons. Clearance must be checked with other pistons. Also check clearances when using larger valves or when other modifications have been done to the head.

#### VALVE TO PISTON CLEARANCE MINIMUMS:

Intake .040" - .050" EXHAUST .050" - .060"

These are minimums. More is better. Clearances should be increased on high RPM engines.

\*Should be at least .040"

\*\* Should be at least .040" between coils

# POWROLL Camshaft Installation Instructions

## FIRST AND MOST IMPORTANT! READ AND UNDERSTAND ALL INSTRUCTIONS *BEFORE* ATTEMPTING INSTALLATION!

Clean and inspect all valve train parts (both new and used). If any items appear worn or marginal, replace them before attempting to install cam.

### CHECK THE FOLLOWING ITEMS

- ✓ Timing chain: If worn, it will affect valve timing, could jump time and may cause the valves to hit the piston.
- ✓ ROCKER ARMS SHOULD BE REPLACED WHEN INSTALLING A NEW CAMSHAFT. Worn rockers MUST be replaced or the new cam will be damaged.
- ✓ Some cams require high performance valve springs and/or shortened guides. If your Powroll cam does not require performance valve springs, test your stock springs. Springs over 3 years old should be replaced.

### CAM INSTALLATION

**OIL NOTE** - Please use a premium grade (SAE 40 or 50) petroleum *racing motorcycle oil*, we do not recommend any type of synthetic oil. Your choice of oil means the difference between many years of trouble-free performance, and an engine that breaks down in a short period of time.

- ♦ The new cam lobes, rocker pads, and valve stem tips should all be pre-lubed before installation. You should use a moly-based cam installation lube (available at your local auto parts store). If none is available, you may use a LIGHT film of moly grease instead.
- ♦ XR200 – 12701 Camshaft – This cam comes with a new needle bearing bushing which is an upgrade from the stock bushing. For proper alignment, use the stock thrust washer on the large end of the cam.

- ♦ When the parts are adequately lubed, install the cam sprocket(s) on the appropriate marks. You should set the engine at TOP Dead center (TDC) before trying to align the timing marks. Powroll cams are designed to be installed on the stock marks, but it is always advisable to “degree in” any new camshaft. Please refer to the timing card supplied with your cam for the proper specs. Use red Loctite® on cam sprocket retaining bolts. Warrior Camshafts – Make sure to use Red Loctite® on the cam sprocket retaining bolt. You don’t want to know what happens if this comes loose!

- ♦ The valve adjustment specifications for your Powroll cam may be different than your stock specs. Please refer to the front of this timing card. Normally, a high performance cam will require slightly greater clearances than the stock one. Check valve adjustment when the engine is cold.

- ♦ When everything is installed and adjusted carefully, rotate the engine several times using the kickstarter or a wrench on the end of the crankshaft. Listen carefully and try to feel for any mechanical interference between the valves and piston. If the engine will not turn over, or you hear/feel any interference, DO NOT FORCE IT! Return the crank to TDC by rotating in the opposite direction. Determine the cause of the interference by inspection, and/or claying the top of the piston.

- ♦ When re-sealing the top cover, use the correct grade of sealant (Honda Bond, Yamabond #4, or their equivalent). **DO NOT USE COMMONLY AVAILABLE SILICONE SEALERS** some silicone sealers have the annoying habit of falling off and lodging themselves in the oiling system, which will ruin an engine!

- ♦ After cam installation work is completed, you should change the oil and filter prior to starting the engine (see oil notes above). Before starting the engine, gently kick it over until fresh oil gets to the top end. Check this by looking into the head through a valve adjustment cover, or by loosening one of the oil line fittings (if so equipped). Only when fresh oil is visible at the top end should you

*(Continued on last page)*

**Your Powroll cam spec sheet lists clearances that need to be checked. This booklet explains how to perform those checks.**

**1: OK TO INSTALL CAM ON STOCK TIMING MARKS?**

Yes: All Powroll camshafts are designed to be installed on stock timing marks.  
 No: Follow special instructions included with your Cam Spec Sheet.

**2: OK TO USE STOCK VALVE SPRINGS?**

Yes: Install with new or used springs in good condition.  
 No: Install with recommended Powroll spring kit.

**3: MUST CHECK THAT CAM WILL ROTATE WITHOUT INTERFERENCE**

Yes: Always check:

1st: Check Powroll or other valve spring kits as follows:

Measure & record the measurements of the distances C & D (fig 1). This is minimum length measured at full valve lift of the inner (C) and outer (D) spring. Compress each spring in a bench vise and measure the length. The compressed spring length must be at least .040" less than the dimensions of (C & D). It may be necessary to remove some spring shims, or install other springs.

2nd: Position camshaft in its bearings and hand rotate (with rockers, bucket etc. removed.

Also easier with valves and springs removed) to test for free 360-degree rotation, if any lobe contact is noted, material must be ground away from head, cam tower or rocker box as required to assure .010" minimum clearance at all points.

3rd: With camshaft installed, install rocker arms, buckets, etc. Holding rocker arm against cam lobe, rotate cam and check for any interference at point A (fig. 2). Grind underside of rocker arm to assure at least .010" clearance.

**4: MUST CHECK FOR SPRING RETAINER TO VALVE GUIDE CLEARANCE?**

No: Okay with recommended spring kit ONLY. Check with others.

Yes: Install valve in head but substitute a light spring (a carb slide spring works well), Be sure any valve spring shims or seat washers are in place, set valve lash at zero. Slowly hand rotate camshaft until the Exhaust valve(s) open completely; Check for clearance between the valve spring retainer and the top of the valve guide or stem seal (point B, fig. 1). Repeat for Intake valve(s). Minimum clearances are listed on your Cam Spec. Sheet. In some cases, it may be necessary to replace or shorten the guides.

**5: MUST CHECK FOR VALVE TO VALVE CLEARANCE?**

No: This clearance is OK if used with stock valves in a stock head, but always check for a minimum of .025" between the valves at overlap.

Yes: If any contact is noted, either sink valves into head (cut seats deeper) or reduce valve diameter for necessary clearance (see Oper #1, fig. 3). Slightly above seat area, make 45 degree cut angled toward valve centerline (Oper #2, fig. 3).

**6: VALVE TO PISTON CLEARANCE WITH THIS CAM**

Powroll pistons are cut for clearance with our camshafts. Any changes to the piston, deck height, valve size, etc. will require a clearance check.

Remove the head. Insert small pieces of clay into the valve pockets (if you are installing a high compression piston or have modified the cylinder or head, you will want to clay check the dome, spark plug, and squish area of the piston also. After adding clay to the piston, install the head with the same setup as #5 above. Torque the head to proper specifications. Rotate the crankshaft slowly forward by hand through two complete revolutions. Remove the head and measure the clay. Compare to minimums shown on your Cam Spec. Sheet.

Machine the piston to maintain at least minimum clearances.

Check dome/pocket thickness before and after cutting.

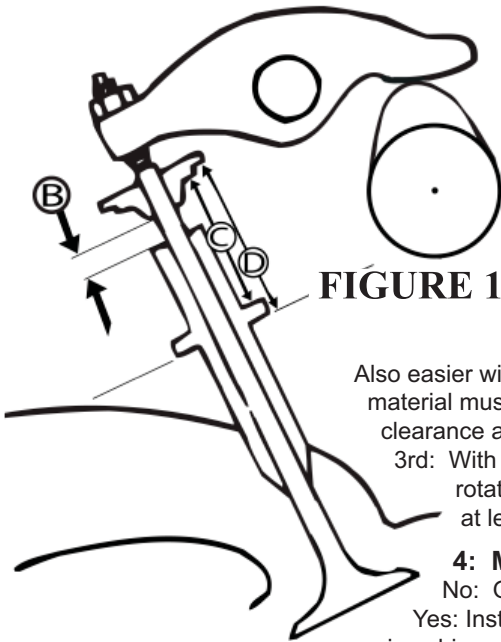

**FIGURE 1**

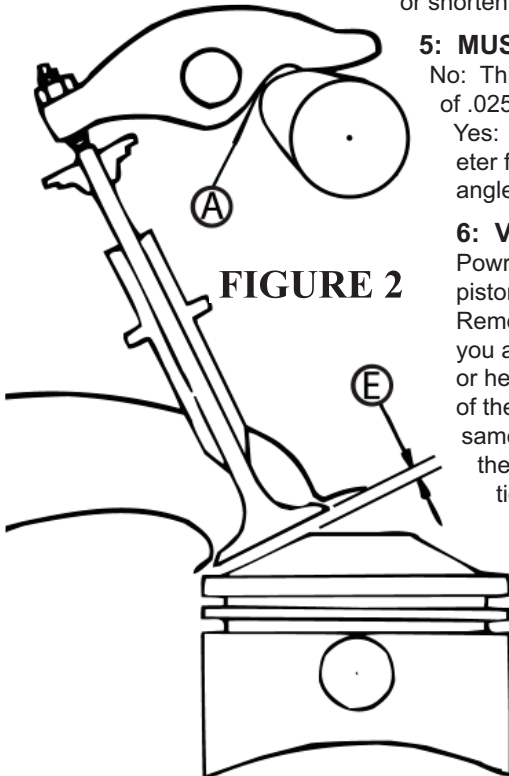
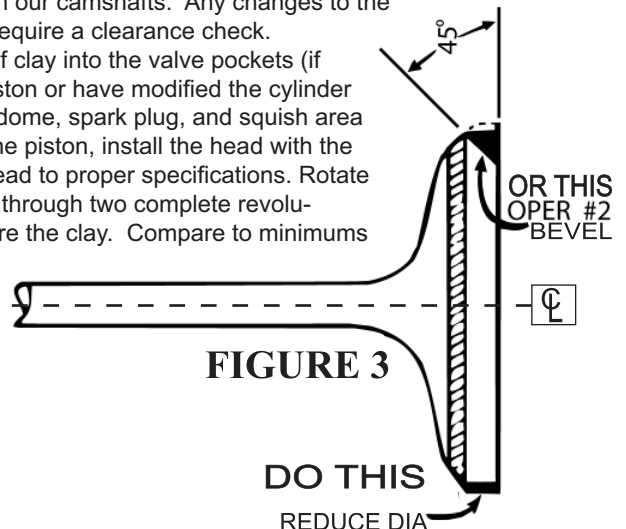
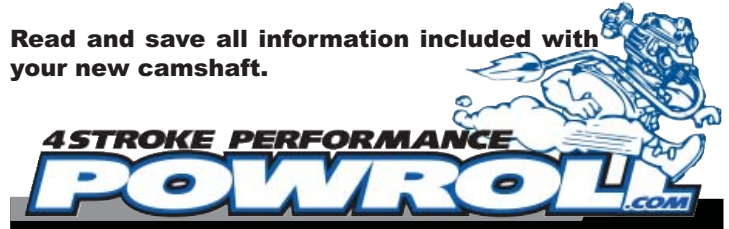

**FIGURE 2**

**POWROLL = 4 Stroke Performance!**  
 PO Box 920 Redmond OR 97756  
 (541) 923-1290 www.powroll.com

**HIGH PERFORMANCE  
 CAM INSTALLATION  
 INFORMATION**

Read and save all information included with your new camshaft.



**FIGURE 3**